

# ECOLOGY LETTERS

Volume 10 Number 2 | February 2007



Blackwell  
Publishing



CENTRE NATIONAL  
DE LA RECHERCHE  
SCIENTIFIQUE

REVIEW AND  
SYNTHESISLiving in the branches: population dynamics and  
ecological processes in dendritic networks

Evan H. Campbell Grant,<sup>1,2</sup>  
Winsor H. Lowe<sup>3</sup> and William F.  
Fagan<sup>4</sup>

<sup>1</sup>USGS – Patuxent Wildlife  
Research Center, 12100 Beech  
Forest Road, Laurel, MD 20708,  
USA

<sup>2</sup>Department of Marine,  
Estuarine and Environmental  
Sciences, University of Maryland  
College Park, College Park, MD  
20742, USA

<sup>3</sup>Division of Biological Sciences,  
University of Montana,  
Missoula, MT 59812, USA

<sup>4</sup>Department of Biology,  
University of Maryland College  
Park, College Park, MD 20742,  
USA

\*Correspondence: E-mail:  
ehgrant@usgs.gov

**Abstract**

Spatial structure regulates and modifies processes at several levels of ecological organization (e.g. individual/genetic, population and community) and is thus a key component of complex systems, where knowledge at a small scale can be insufficient for understanding system behaviour at a larger scale. Recent syntheses outline potential applications of network theory to ecological systems, but do not address the implications of physical structure for network dynamics. There is a specific need to examine how dendritic habitat structure, such as that found in stream, hedgerow and cave networks, influences ecological processes. Although dendritic networks are one type of ecological network, they are distinguished by two fundamental characteristics: (1) both the branches and the nodes serve as habitat, and (2) the specific spatial arrangement and hierarchical organization of these elements interacts with a species' movement behaviour to alter patterns of population distribution and abundance, and community interactions. Here, we summarize existing theory relating to ecological dynamics in dendritic networks, review empirical studies examining the population- and community-level consequences of these networks, and suggest future research integrating spatial pattern and processes in dendritic systems.

**Keywords**

Cave network, dendritic ecological network, dispersal, ecosystem function, hedgerow network, population and community processes, road network, spatial structure, stream network.

*Ecology Letters* (2007) 10: 165–175

**INTRODUCTION**

Ecologists' interest in spatial processes has grown tremendously over the last few decades (MacArthur & Wilson 1967; Fretwell 1972; Forman & Godron 1986; Hanski & Gilpin 1997; Clobert *et al.* 2001). Attention has focused especially strongly on issues relating to habitat geometry, such as patch size (Skellam 1951; Hanski & Ovaskainen 2000; Speirs & Gurney 2001), patch edges (Fagan *et al.* 1999; Ries *et al.* 2004), and corridors (Haddad *et al.* 2003). In metapopulations, mainland-island networks, and other multi-patch systems, substantial effort has centred on characterizing and quantifying aspects of ecological connectivity that influence the flow of genes and individuals, and that regulate ecosystem services. Empirical and theoretical investigations of the interaction between habitat configuration and ecological processes, such as population growth and spread, are becoming more prevalent in ecology and

conservation biology (e.g. Hanski 1998; With 2002). Here, we (1) review current paradigms and tools for studying complex systems; (2) describe a specific, important class of networks where hierarchical, branching geometry imposes special structural and dynamic properties; (3) summarize existing theory relating to ecological dynamics in these dendritic networks; (4) review empirical studies examining the population- and community-level consequences of dendritic ecological networks (DENs); and (5) suggest future research integrating spatial pattern and processes in these networks.

Recent syntheses have applied network theoretic analyses to understand the functioning of a diverse set of complex systems (Newman 2003; Stewart 2004; Proulx *et al.* 2005; May 2006; Montoya *et al.* 2006) suggesting that emergent characteristics, such as system-level responses to disturbance, can be predicted from the structure of a network and the strength of interactions among network elements. These

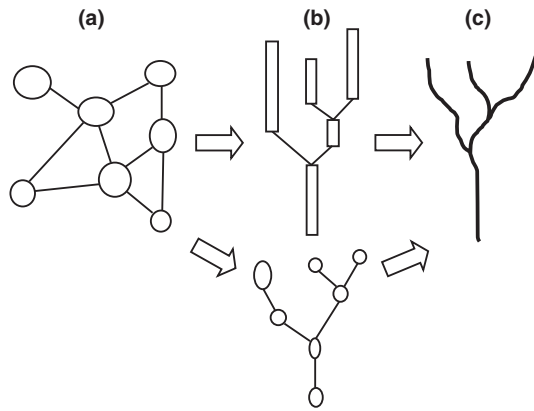

**Figure 1** Types of spatial networks considered in this review. Lattice networks (a) are often represented as a system of patches and links. In this conceptual model, patches represent populations or other subunits of a system, and links function as pathways of dispersal or interaction. Dendritic networks (c) are distinctly different from lattice networks in that the links (or ‘branches’) are no longer mere representations of functional interaction, but are instead primary habitat. Likewise, the nodes of dendritic networks are transfer points between branches, and often constitute distinct types of habitat themselves. Representation of dendritic networks using existing conceptual models [e.g. with stream reaches as habitats (b, upper) or confluences as nodes (b, lower)] may be insufficient to capture the key features inherent to ecological networks with dendritic geometry (c).

reviews constitute a coherent treatment of ‘lattice’ networks, which are node-focused systems in which the role of network links is to connect processes that occur within the system of nodes (Fig. 1a). Lattice networks include rasterized networks, in which each cell in a regular spatial grid is connected to a fixed number of neighbours, as well as patchy networks, in which each patch is (potentially) directly connected to all other patches in the network. Thus, our use of the term ‘lattice’ includes those systems that lie between a random graph and a regular spatial lattice (e.g. a ‘small world’ network, Watts & Strogatz 1998).

Ecologists have utilized theory developed for complex networks in other systems to understand dynamics in spatially structured ecological networks. One such framework involves the application of a field of mathematics known as graph theory (Urban & Keitt 2001, also referred to as network theory: Newman 2003 and references therein), a set of tools that offer substantial advantages in studies of ecological connectivity (Calabrese & Fagan 2004). In graph theory, spatially structured systems can be idealized as a system of ‘nodes’ and ‘links’ (also called ‘edges’; not to be confused with habitat edges, as in landscape ecology), and spatial ecologists working with graph theory have generally viewed nodes as discrete habitat patches and the links as the

connections along which individuals or resources flow. This conceptual framework has been applied to spatially structured networks with lattice-like topology to identify important habitats for metapopulation conservation (Urban & Keitt 2001), to investigate the response of migration corridors to the positioning of stopover sites (e.g. bird migration routes, Shimazaki *et al.* 2004), or to forecast the response of a population to landscape change (e.g. amphibian population response to drought, Fortuna *et al.* 2006).

In contrast to the wide theoretic interest in spatially structured networks with lattice-like architecture, there has been little discussion of systems with alternative network geometries, such as the dendritic (branching) geometry common to plants, river systems, and caves. This lack of attention may arise because, from a theoretical standpoint, dendritic geometries are merely a special case of network topology. However, dendritic geometries are widespread in ecological systems and feature particular structural and dynamic characteristics that deserve special attention. Dendritic ecological networks are a unique type of spatially structured network, which differ from lattice networks in several important ways (Table 1).

Recent theoretical advances in spatially structured networks focus primarily on the development of statistical indices of network properties (Newman 2003) that contribute to large-scale connectivity and, therefore, to network-level persistence of populations (e.g. Jordán *et al.* 2003; Pascual-Hortal & Saura 2006). However, ecological processes in DENs are sensitive to specific structural features of the network that are obscured by these statistical indices. This sensitivity results, in part, because in DENs there is a closer match between the physical scale at which the network is considered and the scales at which ecological processes are acting. This sensitivity also underscores the importance of developing alternative tools for exploring and understanding ecological dynamics in DENs.

## WHAT ARE DENDRITIC ECOLOGICAL NETWORKS?

‘Dendritic’ describes the geometric pattern of arborescent bifurcation, consisting of a ‘mainstem’ and ‘branches’ which decrease in size and increase in number hierarchically as one proceeds upwards through the network (Fig. 1c). Many DENs are fractal-like, with elements of self-similarity across scales. The classic example of dendritic geometry in nature is the branching architecture of individual plants (Thompson 1917). However, the hierarchical branching geometry of stream systems has received considerable attention regarding the relationship between network geometry and dynamics (Fisher 1997; Rodríguez-Iturbe & Rinaldo 1997; Fisher *et al.* 2004).

From this background, the DEN concept can be generalized to describe any system where critical resources

**Table 1** Conceptual contrasts between spatially structured lattice networks and dendritic ecological networks

Lattice networks	Dendritic networks
Nodes (patches) and edges (links) are discrete features, with nodes as habitat and edges as functional links between habitat patches	Both nodes and edges (branches) are habitat, with branches as primary habitat patches
Primary movement between habitat patches (edges or links)	Primary movement along network branches
All connections possible, provided they satisfy constraints specific to the species or individual (e.g. dispersal distance, matrix permeability)	Movement generally restricted to occurring along the network branches. Out-of-network connections sometimes possible (depending on species, life stage, branching geometry of the network)
Geometry of habitat patch layout affects processes and patterns in the network	Geometry of branching affects processes and patterns in the network
Movement through the network constrained by inter-patch distance and conditions in the non-habitat matrix between patches	Movement through the network primarily a function of distance following the network branches and branching geometry
Patches of varying shapes	Elements of habitat largely linear

are concentrated in a linear arrangement and where those linear subunits intersect to create a branching architecture. This structure may result from landscape alteration that maintains linear units of distinct habitat, for example, hedgerows and fence lines (Hilty & Merenlender 2004; Deckers *et al.* 2005), the formation of caves by dissolution in karst landscapes (Christman *et al.* 2005), or the construction of transportation corridors (Christen & Matlack 2006). Although not dendritic in the strict sense, hedgerow and transportation corridors exhibit key structural features of other natural dendritic networks, such as streams or caves.

In systems structured as DENs, ecological processes (e.g. dispersal, population growth and community interactions) are carried out within the branches themselves, while the nodes serve as 'transfer' points where branch dynamics may be modified as one proceeds along the network. These processes may change depending on branch size, the juxtaposition of different branch types at nodes, and the interplay between species (or individuals) and network geometry. This conceptualization means that DENs are structurally and functionally different from other types of ecological networks, such as metapopulations and food-webs, where the focus is largely on the nodes of the network, with links that define connections between nodes (Table 1; Polis & Winemiller 1996; Hanski 1998; Ricketts 2001). For example, within DENs such as river or cave networks, branches serve as primary habitats for resident species, whereas in lattice-type spatial networks, the links are typically routes for connections between habitats. Furthermore, when links exist as discrete features in lattice networks, they are typically of lower quality (e.g. movement corridors between patches). As we discuss below, the branching, hierarchical geometry of DENs drives key patterns and functional properties.

Because these structural differences are difficult to incorporate explicitly in lattice models, conclusions drawn

from these models may not be applicable to DENs. Graph theoretic approaches have great potential in studies of spatially structured lattice networks (e.g. metapopulations; Urban & Keitt 2001), but such approaches are of limited utility in studies of DENs, where spatially constrained network topology and hierarchical geometry interact. In some cases, representation of a DEN as habitat branches linked at the branch intersections (Fig. 1b, upper) may be appropriate when interest is focused on dynamics within the linear habitat units alone. Likewise, when interest is focused on dynamics and processes occurring at habitat intersections, a DEN can be conceptualized as nodes linked by habitat branches (Fig. 1b, lower). However, such graph theoretic perspectives will obscure processes that are functions of both nodes and branches. Accounting for the interaction of these two fundamental network components is critical to understanding ecological dynamics in DENs.

## DYNAMICS IN DENDRITIC ECOLOGICAL NETWORKS

Identification of general patterns resulting from network architecture provides a way to move beyond a case-by-case analysis of the consequences of spatial patterning in ecological systems. Just as consideration of network topology has improved understanding of food webs (Dunne *et al.* 2002; Power & Dietrich 2002) and metapopulations (e.g. Fortuna *et al.* 2006), we argue that further study of DENs as a class of spatial structures will improve our understanding of ecological systems that involve branching, hierarchical geometries. Most empirical studies of dendritic geometry have dealt with stream systems, though other types of systems also fit the general topological form of a DEN. We believe that developing a conceptual framework for these types of networks will

(1) guide development of theory suitable for DENs, and (2) provide direction for studies in a diverse set of systems where branching, hierarchical geometries are important. Because the architecture of a DEN is usually rigid and ecological processes occur in the network branches, the network imposes constraints on population processes such as spread, growth and survival (Fig. 2). By influencing the population dynamics of individual species and by differentially mediating the movement of species among branches, the network architecture of DENs may also affect community dynamics (Fig. 2).

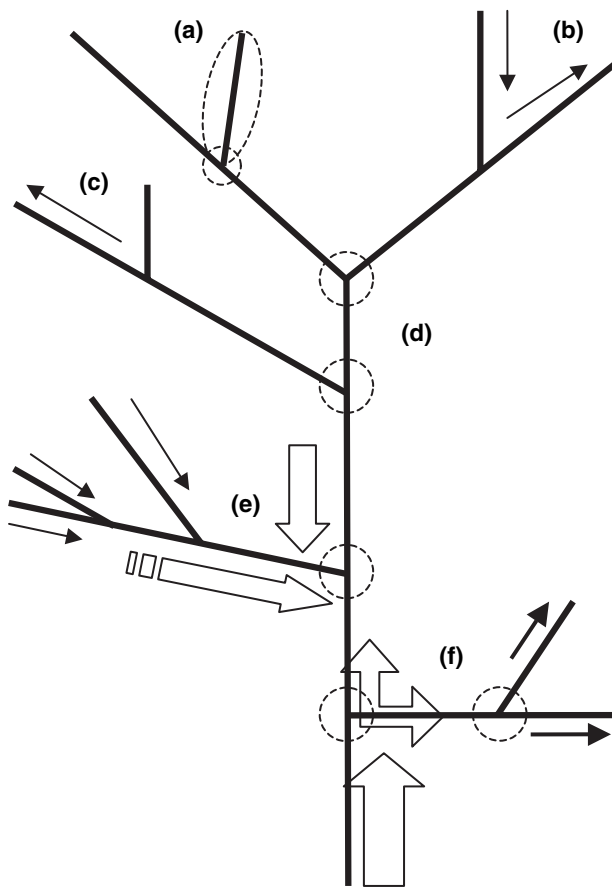

**Figure 2** Conceptual diagram of population and community processes in dendritic ecological networks. Dendritic networks are unique in that both ‘nodes’ and ‘branches’ serve as habitat (a). A principal consequence of dendritic architecture is to alter patterns of dispersal. For example, dendritic geometry may facilitate rescue of declining populations (b), alter vector stopping rules (c), and enhance diversity at ‘nodes’ (confluence points) by providing heterogeneity in resource distribution (d), or as a function of advective displacement (e). The spatial isolation imposed by the branching geometry of the network may also interact with individual mobility to slow spatial spread along the network (f).

### Population-level implications of dendritic network structure

In a DEN, connectivity is a function of network topology, which interacts with species- and individual-level behaviours. Individual movements can follow two pathways in dendritic networks: along the network geometry (within-network movement), or between branches of the network (out-of-network movement). For example, while larval stream insects are restricted to within-network movements (e.g. Waters 1972), many adult stream insects are capable of out-of-network movement by flying overland among branches (Miller *et al.* 2002; Macneale *et al.* 2005). For some species, such as stream amphibians, certain life stages are capable of both in- and out-of-network movement. A variety of taxa exhibit preferential movement paths along the branches of habitat networks (e.g. butterflies in open, non-forest habitat, Haddad 1999; organisms moving across migration networks, Alerstam 2006; migrating fish, Keefer *et al.* 2006), suggesting that organisms respond to structural cues within the habitat network. For example, Keefer *et al.* (2006) found that migrating, radio-tagged Chinook salmon (*Oncorhynchus tshawytscha*) selectively used those portions of the rivers that exhibited cues of their natal tributaries. Where in the river network individuals began to use chemical cues to navigate towards their natal tributary depended on the size (and discharge) of their natal tributary and the proximity of dams in the mainstem that could alter directional cues via mixing and turbulent flow. Additionally, in a habitat with stark boundaries between habitat and non-habitat, Haddad (1999) found that butterfly movement behaviour at habitat patch boundaries was a good predictor of the use of habitat corridors through non-habitat matrix. He observed that species whose movement behaviour suggested reflection off the patch boundary were likely to move through habitat corridors. These examples illustrate the types of spatially referenced cues that organisms may use to facilitate movement through the linear habitat features in a DEN.

For species that preferentially travel along the network branches, patterns of genetic relatedness can reflect the constraints imposed by the network architecture (Rissler *et al.* 2004; Lowe *et al.* 2006). When species are obliged to move within the network, strong demographic and genetic isolation may occur among locations that are nearby in Euclidean space, but distant along network branches (Fagan 2002; Rissler *et al.* 2004). In cave networks, populations of obligate cave-dwelling organisms may be isolated if networks of underground passages are extensive, even when cave entrances are separated by short above-ground distances. As cave animals are restricted to subterranean pathways, the branching architecture of cave networks imposes a structural constraint on dispersal which may explain the high levels of endemism in this group of organisms (Christman *et al.* 2005).

For example, Fong & Culver (1994) described the distribution of several cave-dwelling aquatic crustaceans and ascertained the history of species' invasion of the network by mapping the occurrence of each species in relation to the network's branching geometry. The distribution of one species (*Gammarus minus*) was best explained by movement upstream through the branching cave network. This pattern of movement resulted in occupancy of only a portion of the network of cave passages, even when surface connections with the adjacent cave passages were nearby in Euclidean space. Another species (*Caecidotea bolsingeri*) was postulated to have invaded the cave network from the tips of the network branches, as suggested by its contemporary distribution throughout the cave network.

The linear habitat arrays of a DEN can also enhance population connectivity by acting as movement corridors, which channel dispersal along pathways of suitable habitat (Fig. 2b; Beier & Noss 1998; Joyce *et al.* 1999). The enhanced connectivity of a DEN can increase the likelihood of metapopulation persistence, provided dispersal is sufficient to recolonize extirpated patches (Fagan 2002). Similarly, the topology of a network of habitat patches may interact with dispersal vectors and species' life history traits to influence the rate and extent of population expansion (Cuddington & Yodzis 2002). Empirical evidence of high population connectivity in DENs includes rates of seed spread via the edge-following behaviour of birds (Levey *et al.* 2005), the distribution of plant communities along riverbanks and within hedgerows (Honnay *et al.* 2001; Deckers *et al.* 2005), the preferential flight orientation of emerging stream invertebrates (Macneale *et al.* 2004, 2005), and the recovery of salamander populations following logging in headwater drainages (Lowe & Bolger 2002). In European hedgerows, the probability of pin cherry (*Prunus pensylvanica*) occurrence increased near nodes where hedgerows intersected. This pattern was attributed to the edge-following behaviour of birds that serve as the tree's primary seed dispersal vector (Deckers *et al.* 2005). Likewise, the presence of confluent or intersecting branches may enhance the size and demographic resilience of a population (Fig. 2b) by providing a ready source of colonists (the rescue effect of Brown & Kodric-Brown 1977) or through transient source-sink dynamics (Pulliam 1988). For example, Lowe & Bolger (2002) found that networks with greater complexity (e.g. networks having confluent branches vs. linear, unbranched networks) harboured larger populations of a stream salamander species (*Gyrinophilus porphyriticus*) that is primarily limited to movement along the network branches.

Organisms searching for high quality habitat may take advantage of spatially referenced clues. In DENs, node habitats often feature distinct physical and chemical conditions that may create high quality habitat at nodes, or provide information on habitat quality in the intersecting

branches (Fig. 2d,e; e.g. Joyce *et al.* 1999; Liu *et al.* 2003; Benda *et al.* 2004; Keefer *et al.* 2006). For example, Riffell & Gutzwiller (1996) found that the shape of hedgerow intersections influenced plant species richness, with more intersecting branches correlating with higher richness. In these hedgerow systems, such 'intersection effects' were a result of both the unique abiotic conditions at the nodes and the increased chance of seed deposition by bird and mammal dispersal vectors at those nodes with many branch intersections. Such intersection effects in hedgerows are particularly strong in carabid beetles, which were more abundant at those habitat nodes with many branch intersections than in the confluent branches (Joyce *et al.* 1999). Likewise, in stream networks, two-lined salamander larvae (*Eurycea bislineata*) and all life stages of the northern spring salamander (*Gyrinophilus porphyriticus*) prefer microhabitats in headwater streams with low proportions of fine particles, which can limit the suitability of the stream bed as a refuge from predatory fish (Barr & Babbitt 2002; Lowe & Bolger 2002). Disturbance in upstream tributaries can result in greater deposition of fine sediments at nodes (Benda *et al.* 2004), which may prevent salamanders from moving through those nodes and into upstream tributaries.

The spatial pattern of disturbance is also likely to have a strong affect on population connectivity in DENs. For example, in stream networks, Euclidean (i.e. overland) distances between adjacent, low-order streams (e.g. headwaters) are typically shorter than distances to the same point if travelling along the network branches. Therefore, in species that are restricted to within-network movements (e.g. most fish), the likelihood of recolonization following disturbance will increase as the size of the impacted stream decreases (Fagan *et al.* 2002; Fagan 2002). Likewise, in cave systems, populations may be sensitive to disturbances that are correlated in space, when surface entrances to branches of the cave network are nearby in Euclidean distance. In this way, the architecture of the DEN impedes recolonization of the branch tips by inducing a mismatch between the dispersal ecology of a species (which is restricted to movements along the network branches) and the spatial pattern of disturbance in the network (Fagan 2002). Furthermore, due to the hierarchical geometry of DENs, a disturbance in one branch segment may be more easily translated through the network (Jones *et al.* 2000). Such connectivity results in correlated extinction risks for branches along the network, and will likely be most severe in directed systems (e.g. streams).

The dynamics of an invasion can also be sensitive to the underlying geometry of a DEN. In a complex network, a population undergoing diffusion will be partitioned between (1) movements along the main stem of the network and (2) spread to the branches (Fig. 2; Johnson *et al.* 1995). In this

way, the branches may act as population ‘sinks’ (Pulliam 1988), preventing rapid spread through the network. This feature may be especially important in understanding the spread and dynamics of diseases in DENs. Furthermore, network geometry and complexity allow for increased equilibrium densities of prey populations, especially when predator movement is limited (Cuddington & Yodzis 2002). Out-of-network connectivity may remove the restrictions imposed by network architecture (Cuddington & Yodzis 2000), and this increased topological connectedness may enhance dynamic stability of the network (Csermely 2004). Such results would be qualitatively similar to theoretical models of metapopulation dynamics occurring in dendritic networks (e.g. Fagan 2002; Lowe 2002). In a theoretical investigation of the effect of dendritic network geometry on population persistence, Fagan (2002) studied the influence of network topology on extinction risk in dendritic and linear (unbranched) networks, simulating the response of species that only move along the network branches. He found that when colonization probability was small relative to extinction, the shape of the network did not change the metapopulation extinction risk. However, when colonization probability was high and not directed (i.e. individuals could move both upstream and downstream through the network), population persistence times were enhanced in the dendritic system, highlighting the importance of network geometry. Additionally, Lowe (2002) included a small probability of out-of-network movement (i.e. movements that did not follow the network branches) in his model of metapopulation dynamics in DENs. He found that when a population was concentrated in the uppermost branches of the network (as may be common in stream salamanders), this out-of-network dispersal was important in promoting stability of the population in the network. These results highlight the importance of network architecture on regulating ecological processes such as movement and colonization. Furthermore, in species or life stages capable of out-of-network movements, the interaction between population distribution and the bifurcation angles of habitat branches in a DEN may play a key role in regulating spread to adjacent branches. More theoretical work is needed to understand the range of conditions under which dendritic geometry enhances dynamic stability of ecological systems.

### Community-level implications of dendritic network structure

Because dendritic geometry constrains local patterns of movement, and may do so differentially among species, the physical structure of a DEN may strongly influence interspecific interactions. In dendritic networks, the complexity of the network architecture can impede the move-

ment of individuals (Johnson *et al.* 1995), which can reduce predator–prey interaction rates (Cuddington & Yodzis 2002). This results from the interaction of environmental attributes (i.e. the geometric complexity of the network) with the movement behaviour of individuals, which only have local spatial knowledge and cannot perceive the overall structure of the network. Within a geometrically complex network, predators may be unable to respond to spatial variation in prey population density, increasing the variation in local reproductive rates, persistence and equilibrium densities of prey populations (Cuddington & Yodzis 2002). The link between dendritic geometry and species interactions is especially well developed in insect–plant systems (e.g. Kareiva & Sahakian 1990; Grevstad & Klepetka 1992). Many attributes of plant architecture may affect species interactions, including size and gross morphology, number and variety of plant parts, and number of physically touching (connected) parts (Grevstad & Klepetka 1992; Gingras *et al.* 2002; Marquis *et al.* 2002; Legrand & Barbosa 2003). In an experimental test of the influence of network architecture on parasitoid–host interactions, Gingras *et al.* (2002) constructed artificial plants of varying geometric complexity, and evaluated the influence of plant architectural complexity on parasitism rate. They found that increasing connectedness (defined as the number of nodes present in the plant’s architecture) reduced the rate of parasitism by decreasing the efficiency of locating a host. The parasitoid found hosts by walking along the branches of the plant, and therefore, increasing the number of connections decreased the encounter rate and the probability of finding a host in a given unit of time (Fig. 2f). Legrand & Barbosa (2003) reported similar results in an aphid–predator system, and attributed the persistence of aphid populations on structurally complex plants (those with a larger number of nodes) to a decrease in predator search area efficiency.

The geometry of intersecting habitat branches influences the distribution of species within the network, and the branching architecture can therefore determine patterns of species diversity. For example, the species richness of electric fish communities of the Amazon River is enhanced at tributary confluences (i.e. nodes; Fig. 2d; Fernandes *et al.* 2004). In general, this enhancement of diversity may depend on the branching patterns of the network (Grenouillet *et al.* 2004), and on the specific dispersal ecology of the species involved (Skalski & Gilliam 2000; Cuddington & Yodzis 2002). In stream networks, the presence of confluent branches at nodes may enhance diversity by (1) providing refugia for sensitive life stages or species; (2) enhancing local habitat heterogeneity; and (3) providing access to the mainstem for migratory individuals. The side branching architecture of stream networks (i.e. lower order branches that link directly to a mainstem; Turcotte *et al.* 1998) affects distributional patterns of fish (Grenouillet *et al.* 2004; Smith

& Kraft 2005) and invertebrates (Rice *et al.* 2001). In these studies, increased local diversity was related to the large-scale branching geometry and spatial arrangement of the stream network rather than tributary presence *per se*. One reason for this relationship may be that the hierarchical branching of stream tributaries affects aspects of habitat structure and water quality both at the tributary confluences and in the mainstem downstream of the confluences (Rice *et al.* 2001; Liu *et al.* 2003; Benda *et al.* 2004). More generally, the nodes of DENs are likely to support high level of species diversity because they represent intersections of distinct habitat types where, consequently, localized habitat diversity is high relative to areas of similar size within network branches.

Network architecture can also influence food web structure (Power & Dietrich 2002; Fisher *et al.* 2004), and three characteristics of DENs seem especially important. First, nodes serve as unique habitats, where resources are concentrated before they are dispersed through the network. Concentration of resources can occur via advective transport or active individual choice for specific habitat conditions at nodes (Fig. 2e), and accumulation of resources at branch junctions may regulate the flux of resources through the network. For example, the effect of persistent downstream movement of material and individuals from tributaries may override competitive interactions further down in the network, resulting in a type of mass-effect (Kunin 1998). Second, the juxtaposition of independent branch habitats provides diverse habitat types and resource flows at nodes, especially where smaller tributaries intersect larger branches (Fig. 2d). Via advection and concentration, smaller branches may provide resource subsidies to organisms that are restricted to larger branches by size or other abiotic habitat requirements ('landscape complementation'; Dunning *et al.* 1992). This effect would likely be highly dependent on the size and configuration of the network branches. Finally, the presence of spatially repeating, but indirectly linked branches introduces a source of spatial heterogeneity in predation pressure and resource availability. Theoretical studies by Cuddington & Yodzis (2002) demonstrated that the topological complexity of DENs alters stopping rules of predators, which can get caught in network branches with depleted resources (Fig. 2b). The architecture of a DEN thus induces a mismatch between scale at which a consumer can respond to the spatial structure of the network and the scale over which resources are distributed within the network.

#### **MOVING BEYOND BRANCHES AND NODES: INTEGRATING PATTERN AND PROCESS IN DENDRITIC NETWORKS**

Compared with lattice networks, networks with dendritic architecture lack a general theory relating to ecological

patterns and processes. Stream ecologists have long recognized that the spatial layout of tributary branches can affect processes in the mainstem (e.g. Vannote *et al.* 1980; Bruns *et al.* 1984; Fisher 1997). However, despite a focus on large-scale spatial structure in riverine systems (Fisher 1997), empirical studies of how dendritic network geometry affects ecological patterns and processes in these systems are rare. Empirical examinations of the role of spatial structure in other types of DENs are similarly sparse. Indeed, our review revealed only a handful of studies dealing with the influences of plant architecture, cave, or hedgerow networks on population or community level dynamics.

Much of the work on lattice networks falls into a few broad categories: (1) mechanisms for the formation of complex networks; (2) assembly characteristics for attachment of links to nodes (e.g. preferential addition of links to highly connected nodes); (3) properties of the network (e.g. robustness to node removal); and (4) the form and function of links (Newman 2003; Proulx *et al.* 2005). Thus, in spatial networks with lattice-type geometry (e.g. Fig. 1a), much of the interest is on features of the landscape that promote or inhibit network connectivity. In contrast, the exciting future for DENs lies in the identification of patterns and processes specific to and resulting from the rigid, branching geometry and the interaction of branches and nodes. Characteristics important to DENs include (1) number of branch intersections; (2) size and shape of branches; and (3) the hierarchical geometry of branching. In particular, more theoretical and empirical efforts are needed to characterize the relationship between dendritic network structure and (1) population dynamics, limitation, and regulation; (2) speciation and evolutionary dynamics and limitations; (3) species extinction risks and conservation; (4) land management and response to disturbance; and (5) species interactions.

Empirical case studies discussed above suggest that the topology of dendritic networks results in special properties and patterns that may be generalized to other systems sharing important features of this network structure (e.g. caves, transportation networks, and potentially, migration routes and corridors). Concern about habitat fragmentation has inspired research into habitat features controlling population connectivity and ecosystem fluxes, such as habitat edges (e.g. Fagan *et al.* 1999) and corridors (e.g. Haddad *et al.* 2003), that can also be addressed within a conceptual framework for DENs. Linking DENs to work in lattice networks would benefit our general understanding of ecological networks, but the rigid geometry of DENs and importance of branches rather than node habitats does not fit well into existing network models for node-focused lattice systems. Regardless, we need a better way to generalize patterns and processes resulting from the geometry of dendritic systems. Looking forward, several topics deserve special attention:



### Within-network vs. out-of-network movements

The fraction of movements taking place within the restrictive geometry of a DEN relative to out-of-network movements (e.g. from one branch to another) is undoubtedly critical to population demography and genetics. For organisms that have evolved within spatially structured systems, within-network movements can reasonably be considered as primary movement pathways, and out-of-network movements as secondary pathways (or 'weak' links; Csermely 2004). However, out-of-network movements may be particularly important for maintaining genetic diversity within populations in DENs (Lowe 2002; Rissler *et al.* 2004), and may be crucial for population persistence, should a dendritic network become fragmented (Fagan 2002). In addition, when species' movements are not constrained by the branching geometry of a DEN (e.g. a greater proportion of out-of-network when compared with within-network movements), measures of community stability will likely increase, as is found in lattice networks with increasing connectance (e.g. Dunne *et al.* 2002).

### Natural vs. human-generated DENs and species adaptation to network geometry

Examples exist of both natural (e.g. streams and desert riparian vegetation) and human-created DENs (e.g. hedgerows). Likewise, we have sets of species that have existed for many generations in DENs and others for which dendritic geometries are a relatively new feature of their landscapes. Consequently, it would be informative to compare the response to disturbance of species that are adapted to dendritic systems with the response of species that have not evolved in spatially structured systems. Large scale, manipulative experiments of network configuration and population abundance or distribution, combined with observational studies on the distribution of organisms in existing natural and manipulated systems, can provide strong inference on the effect of network structure and evolutionary history of species' responses.

### Expanding the scope of DEN models

Most DEN modelling thus far has focused on the dynamics of one or a few species, and almost none of it has been firmly tied to particular systems. One logical area for further modelling efforts is the dynamics of biological invasions, where dendritic geometry can have overriding influences (Johnson *et al.* 1995). Interestingly, dendritic geometry may both facilitate invasions (via corridor-following behaviour) and inhibit invasions (by the presence of side branches). Theoretical studies of the consequences of dendritic geometry are also needed in evolutionary biology. For example, in the

context of DENs, models of speciation, the development of patterns of endemism, and related topics are effectively absent. Because limitations on movement can have such important consequences in evolutionary biology and population genetics in particular, future work should investigate how the specific types of limited movement that arise because of dendritic geometry may affect aspects of species evolution.

### Investigating when geometric details matter

Distributional patterns of a population in a DEN is likely a function of the area and arrangement of intersecting branches, but the nature of these relationships has not been adequately investigated. Decomposing patterns of species distribution in hierarchically structured branches may be aided with a general understanding of the effects of branch area, intersection effects (i.e. number and angles of intersecting branches), and the sequence of branch additions to a network. Better understanding of how an individual or population responds to the network geometry will, for example, elucidate those combinations of life history characteristics, movement preferences and rates, and interactions with the dendritic network architecture that maximize population spread or invasion dynamics in networks of varying complexity (e.g. Cuddington & Yodzis 2002).

### Understanding mechanisms for formation of dendritic networks

Models of dendritic network formation are likely different than in lattice network assembly models (reviewed in Newman 2003), and may provide greater understanding of, for example, biogeographic patterns in species distributions, or species' responses to habitat fragmentation or the addition of habitat corridors. Network formation in a DEN (e.g. dissolution of karst geology, stream capture) may interact with species evolution by reworking network connections in hierarchical dendritic landscapes on timescales comparable with those of speciation processes. Additionally, understanding how natural dendritic systems form may aid efforts to promote landscape level conservation of species over long timescales by identifying movement corridors pre-emptively, even when faced with rapid fragmentation of natural habitats. Combined with an understanding of species' adaptations to DENs, and how species are likely to respond to this network architecture, such perspectives may be a powerful tool in assessing and forecasting the effect of landscape change on natural communities.

### CONCLUSIONS

Recognizing that network geometry may shape ecological patterns and processes will lead to understanding of

system properties that would not be possible by examining the individual parts alone (Proulx *et al.* 2005). Key to this argument is the expectation that specific characteristics of network architecture can be linked to system-wide properties (e.g. small world networks, Watts & Strogatz 1998). In this review, we have highlighted how the definitions and functions of nodes and branches in dendritic networks are distinctly different from those in lattice networks, and illustrated the impacts of this alternative geometry on population- and community-level processes. Overall, a close correspondence exists in DENs between the spatial scale over which the network branches and the scale over which ecosystem processes act. Consequently, the arrangement and dimensions of the network components (habitat branches or patches) should play a large part in regulating the emergent properties of the network as a whole.

A reasonable target for theoretical studies of population dynamics and community processes in spatially structured systems would be the development of a general conceptual framework that encompasses both dendritic and lattice networks. This framework would allow dynamic modelling between network states, where key regulators of ecological processes (such as dispersal) and emergent properties imposed by the dendritic architecture change with the relative contributions of within- and out-of-network connectivity. With this approach, a DEN might function like a lattice network, but this outcome would depend on spatio-temporal dynamics of population, community, and evolutionary processes in the focal system, and would not be pre-determined by network geometry alone. In such an integrative framework, tools from existing network theory would be useful in describing the general characteristics and statistical properties of the network, while understanding of the effect of the specific geometry of the network would come from a dendritic network theory. Borrowing (and modifying) components of lattice network theory may prove a fruitful starting point. Improved understanding of the contribution of network geometry should lead to better understanding of community- and population-level dynamics in systems inherently assembled in DENs, and in those systems that are artificially constrained to this architecture by human activities.

#### ACKNOWLEDGEMENTS

We thank Larissa Bailey, Katia Engelhardt, Jim Nichols, Clint Otto, Margaret Palmer, Katie Schneider and Pamela Toschik for commenting on this manuscript, and for topical expertise that aided sections of the manuscript. The comments from Jon Chase and three anonymous referees greatly improved the manuscript. This work was supported

by the Northeast Amphibian Research and Monitoring Initiative of the United States Geological Survey.

#### REFERENCES

- Alerstam, T. (2006). Conflicting evidence about long-distance animal navigation. *Science*, 313, 791–794.
- Barr, G.I. & Babbitt, K.I. (2002). Effects of biotic and abiotic factors on the distribution and abundance of larval two-lined salamanders (*Eurycea bislineata*) across spatial scales. *Oecologia*, 133, 176–185.
- Beier, P. & Noss, R.F. (1998). Do habitat corridors provide connectivity? *Conserv. Biol.*, 12, 1241–1252.
- Benda, L., Poff, N.L., Miller, D., Dunne, T., Reeves, G., Pess, G. *et al.* (2004). The network dynamics hypothesis: how channel networks structure riverine habitats. *BioScience*, 54, 413–427.
- Brown, J.H. & Kodric-Brown, A. (1977). Turnover rates in insular biogeography: effect of immigration on extinction. *Ecology*, 58, 445–449.
- Bruns, D.A., Minshall, G.W., Cushing, C.E., Cummins, K.W., Brock, J.T. & Vannote, R.L. (1984). Tributaries as modifiers of the river continuum concept – analysis by polar ordination and regression-models. *Arch. Hydrobiol.*, 99, 208–220.
- Calabrese, J.M. & Fagan, W.F. (2004). A comparison-shopper's guide to connectivity metrics. *Front. Ecol. Environ.*, 2, 529–536.
- Christen, D. & Matlack, G. (2006). The role of roadsides in plant invasions: a demographic approach. *Conserv. Biol.*, 20, 385–391.
- Christman, M.C., Culver, D.C., Madden, M.K. & White, D. (2005). Patterns of endemism of the eastern North American cave fauna. *J. Biogeogr.*, 32, 1441–1452.
- Clobert, J., Danchin, E., Dhondt, A.A. & Nichols, J.D. (2001). *Dispersal*. Oxford University Press, Oxford.
- Csermely, P. (2004). Strong links are important, but weak links stabilize them. *Trends Biochem. Sci.*, 29, 331–334.
- Cuddington, K.M. & Yodzis, P. (2000). Diffusion-limited predator-prey dynamics in Euclidean environments: an allometric individual-based model. *Theor. Popul. Biol.*, 58, 259–278.
- Cuddington, K.M. & Yodzis, P. (2002). Predator–prey dynamics and movement in fractal environments. *Am. Nat.*, 160, 119–134.
- Deckers, B., Verheyen, K., Hermy, M. & Muys, B. (2005). Effects of landscape structure on the invasive spread of black cherry *Prunus serotina* in an agricultural landscape in Flanders, Belgium. *Ecography*, 28, 99–109.
- Dunne, J.A., Williams, R.J. & Martinez, N.D. (2002). Network structure and biodiversity loss in food webs: robustness increases with connectance. *Ecol. Lett.*, 5, 558–567.
- Dunning, J.B., Danielson, B.J. & Pulliam, H.R. (1992). Ecological processes that affect populations in complex landscapes. *Oikos*, 65, 169–175.
- Fagan, W.F. (2002). Connectivity, fragmentation, and extinction risk in dendritic metapopulations. *Ecology*, 83, 3243–3249.
- Fagan, W.F., Cantrell, R.S. & Cosner, C. (1999). How habitat edges change species interactions. *Am. Nat.*, 153, 165–182.
- Fagan, W.F., Unmack, P.J., Burgess, C. & Minckley, W.L. (2002). Rarity, fragmentation and extinction risk in desert fishes. *Ecology*, 83, 3250–3256.
- Fernandes, C.C., Podos, J. & Lundberg, J.G. (2004). Amazonian ecology: tributaries enhance the diversity of electric fishes. *Science*, 305, 1960–1962.

- Fisher, S.G. (1997). Creativity, idea generation and the functional morphology of streams. *J. N. Am. Benthol. Soc.*, 16, 305–318.
- Fisher, S.G., Sponseller, R.A. & Heffernan, J.B. (2004). Horizons in stream biogeochemistry: Flowpaths to progress. *Ecology*, 85, 2369–2379.
- Fong, D.W. & Culver, D.C. (1994). Fine-scale biogeography differences in the crustacean fauna of a cave system in West Virginia, USA. *Hydrobiologia*, 287, 29–37.
- Forman, R.T.T. & Godron, M. (1986). *Landscape Ecology*. John Wiley, New York, USA.
- Fortuna, M.A., Gomez-Rodríguez, C. & Bascompte, J. (2006). Spatial network structure and amphibian persistence in stochastic environments. *Proc. R. Soc. B*, 273, 1429–1434.
- Fretwell, S.D. (1972). *Populations in a Seasonal Environment*. Princeton University Press, Princeton, PA.
- Gingras, D., Dutilleul, P. & Boivin, G. (2002). Modeling the impact of plant structure on host-finding behavior of parasitoids. *Oecologia*, 130, 396–402.
- Grenouillet, G., Pont, D. & Herisse, C. (2004). Within-basin fish assemblage structure: the relative influence of habitat vs. stream spatial position on local species richness. *Can. J. Fish. Aquat. Sci.*, 61, 93–102.
- Grevstad, F.S. & Klepetka, B.W. (1992). The influence of plant architecture on the foraging efficiencies of a suite of ladybird beetles feeding on aphids. *Oecologia*, 92, 399–404.
- Haddad, N.M. (1999). Corridor use predicted from behaviors at habitat boundaries. *Am. Nat.*, 153, 215–227.
- Haddad, N.M., Bowne, D.R., Cunningham, A., Danielson, B.J., Levey, D.J., Sargent, S. *et al.* (2003). Corridor use by diverse taxa. *Ecology*, 84, 609–615.
- Hanski, I. (1998). Metapopulation dynamics. *Nature*, 396, 41–49.
- Hanski, I. & Gilpin, M.E. (1997). *Metapopulation Biology*. Academic Press, San Diego, CA.
- Hanski, I. & Ovaskainen, O. (2000). The metapopulation capacity of a fragmented landscape. *Nature*, 404, 755–758.
- Hilty, J.A. & Merenlender, A.M. (2004). Use of riparian corridors and vineyards by mammalian predators in northern California. *Conserv. Biol.*, 18, 126–135.
- Honnay, O., Verhaeghe, W. & Hermy, M. (2001). Plant community assembly along dendritic networks of small forest streams. *Ecology*, 82, 1691–1702.
- Johnson, A.R., Hatfield, C.A. & Milne, B.T. (1995). Simulated diffusion dynamics in river networks. *Ecol. Model.*, 83, 311–325.
- Jones, J. A., Swanson, F.J., Wemple, B.C. & Snyder, K.U. (2000). Effects of roads on hydrology, geomorphology, and disturbance patches in stream networks. *Conserv. Biol.*, 14, 76–85.
- Jordán, F., Báldi, A., Orci, K.-M., Rácz, I. & Varga, Z. (2003). Characterizing the importance of habitat patches and corridors in maintaining the landscape connectivity of a *Pholidoptera transylvanica* (Orthoptera) metapopulation. *Landscape Ecol.*, 18, 83–92.
- Joyce, K.A., Holland, J.M. & Doncaster, C.P. (1999). Influences of hedgerow intersections and gaps on the movement of carabid beetles. *Bull. Entomol. Res.*, 89, 523–531.
- Kareiva, P. & Sahakian, R. (1990). Tritrophic effects of a simple architectural mutation in pea-plants. *Nature*, 345, 433–434.
- Keefer, M.L., Caudill, C.C., Peery, C.A. & Bjornn, T.C. (2006). Route selection in a large river during the homing migration of Chinook salmon (*Oncorhynchus tshawytscha*). *Can. J. Fish. Aquat. Sci.*, 63, 1752–1762.
- Kunin, W.E. (1998). Biodiversity at the edge: a test of the importance of spatial ‘mass effects’ in the Rothamsted Park Grass experiments. *Proc. Natl Acad. Sci. U.S.A.*, 95, 207–212.
- Legrand, A. & Barbosa, P. (2003). Plant morphological complexity impacts foraging efficiency of adult *Coccinella septempunctata* L. (Coleoptera: Coccinellidae). *Environ. Entomol.*, 32, 1219–1226.
- Levey, D.J., Bolker, B.M., Tewksbury, J.J., Sargent, S. & Haddad, N.M. (2005). Effects of landscape corridors on seed dispersal by birds. *Science*, 309, 146–148.
- Liu, S.M., Zhang, J., Chen, H.T., Wu, Y., Xiong, H. & Zhang, Z.F. (2003). Nutrients in the Chengjiang and its tributaries. *Biogeochemistry*, 62, 1–18.
- Lowe, W.H. (2002). Landscape-scale spatial population dynamics in human-impacted stream systems. *Environ. Manage.*, 30, 225–233.
- Lowe, W.H. & Bolger, D.T. (2002). Local and landscape-scale predictors of salamander abundance in New Hampshire headwater streams. *Conserv. Biol.*, 16, 183–193.
- Lowe, W.H., Likens, G.E., McPeck, M.A. & Buso, D.C. (2006). Linking direct and indirect data on dispersal: isolation by slope in a headwater stream salamander. *Ecology*, 87, 334–339.
- MacArthur, R.H. & Wilson, E.O. (1967). *The Theory of Island Biogeography*. Princeton University Press, Princeton, NJ.
- Macneale, K.H., Peckarsky, B.L. & Likens, G.E. (2004). Contradictory results from different methods for measuring direction of insect flight. *Freshwat. Biol.*, 49, 1260–1268.
- Macneale, K.H., Peckarsky, B.L. & Likens, G.E. (2005). Stable isotopes identify dispersal patterns of stonefly populations living along stream corridors. *Freshwat. Biol.*, 50, 1117–1130.
- Marquis, R.J., Lill, J.T. & Piccinni, A. (2002). Effect of plant architecture on colonization and damage by leafyiting caterpillars of *Quercus alba*. *Oikos*, 99, 531–537.
- May, R.M. (2006). Network structure and the biology of populations. *Trends Ecol. Evol.*, 21, 394–399.
- Miller, M.P., Blinn, D.W. & Keim, P. (2002). Correlations between observed dispersal capabilities and patterns of genetic differentiation in populations of four aquatic insect species from the Arizona White Mountains, USA. *Freshwat. Biol.*, 47, 1660–1673.
- Montoya, J.M., Pimm, S.L. & Sole, R.V. (2006). Ecological networks and their fragility. *Nature*, 442, 259–264.
- Newman, M.E.J. (2003). The structure and function of complex networks. *Siam Rev.*, 45, 167–256.
- Pascual-Hortal, L.A. & Saura, S. (2006). Comparison and development of new graph-based landscape connectivity indices: towards the prioritization of habitat patches and corridors for conservation. *Landscape Ecol.*, 21, 959–967.
- Polis, G.A. & Winemiller, K.O. (1996). *Food Webs: Integration of Patterns and Dynamics*. Chapman and Hall, New York, USA.
- Power, M.E. & Dietrich, W.E. (2002). Food webs in river networks. *Ecol. Res.*, 17, 451–471.
- Proulx, S.R., Promislow, D.E.L. & Phillips, P.C. (2005). Network thinking in ecology and evolution. *Trends Ecol. Evol.*, 20, 345–353.
- Pulliam, H.R. (1988). Sources, sinks and population regulation. *Am. Nat.*, 132, 652–661.
- Rice, S.P., Greenwood, M.T. & Joyce, C.B. (2001). Tributaries, sediment sources, and the longitudinal organization of macroinvertebrate fauna along river systems. *Can. J. Fish. Aquat. Sci.*, 58, 824–840.

- Ricketts, T.H. (2001). The matrix matters: effective isolation in fragmented landscapes. *Am. Nat.*, 158, 87–99.
- Ries, L., Fletcher Jr, R.J., Battin, J. & Sisk, T.D. (2004). Ecological responses to habitat edges: mechanisms, models, and variability explained. *Annu. Rev. Ecol. Syst.*, 35, 491–522.
- Riffell, S.K. & Gutzwiller, K.J. (1996). Plant–species richness in corridor intersections: is intersection shape influential? *Landscape Ecol.*, 11, 157–168.
- Rissler, L.J., Wilbur, H.M. & Taylor, D.R. (2004). The influence of ecology and genetics on behavioral variation in salamander populations across the Eastern Continental Divide. *Am. Nat.*, 164, 201–213.
- Rodríguez-Iturbe, I. & Rinaldo, A. (1997). *Fractal River Basins: Chance and Self-Organization*. Cambridge University Press, Cambridge.
- Shimazaki, H., Tamura, M., Darman, Y., Andronov, V., Parilov, M.P., Nagendran, M. *et al.* (2004). Network analysis of potential migration routes for Oriental White Storks (*Ciconia boyciana*). *Ecol. Res.*, 19, 683–698.
- Skalski, G.T. & Gilliam, J.F. (2000). Modeling diffusive spread in a heterogeneous population: a movement study with stream fish. *Ecology*, 81, 1685–1700.
- Skellam, J.G. (1951). Random dispersal in theoretical populations. *Biometrika*, 38, 196–218.
- Smith, T.A. & Kraft, C.E. (2005). Stream fish assemblages in relation to landscape position and local habitat variables. *Trans. Am. Fish. Soc.*, 134, 430–440.
- Speirs, D.C. & Gurney, W.S.C. (2001). Population persistence in rivers and estuaries. *Ecology*, 82, 1219–1237.
- Stewart, I. (2004). Networking opportunity. *Nature*, 427, 601–604.
- Thompson, D.W. (1917). *On Growth and Form*. Cambridge University Press, Cambridge.
- Turcotte, D.L., Pelletier, J.D. & Newman, W.I. (1998). Networks with side branching in biology. *J. Theor. Biol.*, 193, 577–592.
- Urban, D.L. & Keitt, T.H. (2001). Landscape connectivity: a graph-theoretic perspective. *Ecology*, 82, 1205–1218.
- Vannote, R.L., Minshall, G.W., Cummins, K.W., Sedell, J.R. & Cushing, C.E. (1980). The river continuum concept. *Can. J. Fish. Aquat. Sci.*, 37, 130–137.
- Waters, T.F. (1972). The drift of stream insects. *Ann. Rev. Entom.* 17:253–272.
- Watts, D.J. & Strogatz, S.H. (1998). Collective dynamics of ‘small-world’ networks. *Nature*, 393, 440–442.
- With, K.A. (2002). The landscape ecology of invasive spread. *Conserv. Biol.*, 16, 1192–1203.

Editor, Jonathan Chase

Manuscript received 14 August 2006

First decision 2 October 2006

Manuscript accepted 22 November 2006